



**TRUE FOOD SERVICE EQUIPMENT, INC.**

St. Charles Industrial Center • P.O. Box 970 • O'Fallon, Missouri 63366  
 (636)240-2400 • FAX (636)272-2408 • (800)325-6152 • www.truemfg.com  
 Parts Dept. (800)424-TRUE • Parts Dept. FAX# (636)272-9471

Project Name: \_\_\_\_\_

Location: \_\_\_\_\_

Item #: \_\_\_\_\_ Qty: \_\_\_\_\_

Model #: \_\_\_\_\_

A/A #

SIS #

Model:  
**TDB-24-48**

**24" Back Bar/Direct Draw Beer Dispenser**  
*Solid Door*



**TDB-24-48**

- ▶ True's back bar/direct draw combination coolers are designed with enduring quality and value. Our commitment to using the highest quality materials and oversized refrigeration assures colder product temperatures and years of trouble free service.
- ▶ Oversized, factory balanced, refrigeration system holds 33°F to 38°F (.5°C to 3.3°C).
- ▶ Exterior - heavy duty, wear resistant laminated black vinyl front and sides. Matching black aluminum back. All stainless steel counter top.
- ▶ Interior - 300 series stainless steel floor with 1/2" (13 mm) reinforced lip and heavy gauge galvanized steel walls. NSF approved for pre-packaged and bottled product.
- ▶ 3" (77 mm) diameter stainless steel insulated beer column. Cold air is channeled directly into beer column to reduce foaming and maximize draft beer profits.
- ▶ Positive seal doors.
- ▶ Entire cabinet structure and solid doors are foamed-in-place using high density, CFC free, polyurethane insulation.

**ROUGH-IN DATA**

Specifications subject to change without notice.  
 Chart dimensions rounded up to the nearest 1/8" (millimeters rounded up to next whole number).

Model	Doors	Capacity		Shelves	Cabinet Dimensions (inches) (mm)			HP	Voltage	Amps	NEMA Config.	Cord Length (total ft.) (total m)	Crated Weight (lbs.) (kg)
		Left Door 1/2 Barrels	Right Door 12 oz. Cans		L	D	H*						
TDB-24-48	2	1	245	2	49 1/8 1248	23 7/8 607	35 5/8 905	1/3	115/60/1	7.0	5-15P	7 2.1	280 127

\* Height does not include 15 1/4" (388 mm) for draft arm.

<p>10/05 Printed in U.S.A.</p>	<p><b>APPROVALS:</b></p>	<p><b>AVAILABLE AT:</b></p>
--------------------------------	--------------------------	-----------------------------

Model:  
**TDB-24-48**

## 24" Back Bar/Direct Draw Beer Dispenser

*Solid Door*



### STANDARD FEATURES

#### DESIGN

- True's back bar/direct draw combination coolers are designed with enduring quality and value. Our commitment to using the highest quality materials and oversized refrigeration assures colder product temperatures and years of trouble free service.

#### REFRIGERATION SYSTEM

- Factory engineered self-contained, capillary tube system using environmentally friendly (CFC free) 134A refrigerant.
- Extra large evaporator coil balanced with higher horsepower compressor and large condenser; maintains cabinet temperatures of 33°F to 38°F (.5°C to 3.3°C).
- Sealed, cast iron, self-lubricating evaporator fan motor and larger fan blades give True merchandisers a superior low velocity, high volume airflow design. This unique design insures faster temperature pull down of warm product, colder holding temperatures and faster recovery in high use situations.
- Condensing unit accessed from behind front grill, slides out for easy cleaning and maintenance.

#### CABINET CONSTRUCTION

- Exterior - heavy duty, wear resistant laminated black vinyl front and sides. Matching black aluminum back. All stainless steel counter top.
- Interior - 300 series stainless steel floor with 1/2" (13 mm) reinforced lip and heavy gauge galvanized steel walls.

- Insulation - entire cabinet structure foamed in-place using high density, CFC free, polyurethane insulation.
- Welded, heavy duty galvanized frame rail dipped in rust inhibiting enamel paint for corrosion protection inside and out.
- 3" (77 mm) diameter stainless steel insulated beer column. Cold air is channeled directly into beer column to reduce foaming and maximize draft beer profits.

#### DOORS

- Wear-resistant laminated black vinyl exterior with heavy gauge galvanized steel liner.
- Positive seal doors.
- Each door fitted with 12" (305 mm) long recessed handle that are foamed-in-place with a sheet metal interlock to insure permanent attachment.
- Magnetic door gaskets of one piece construction, removable without tools for ease of cleaning.
- Door locks standard.

#### SHELVING

- Two (2) adjustable, heavy duty, black PVC coated wire shelves 17<sup>3</sup>/<sub>4</sub>" L x 18" D (451 mm x 458 mm). Four (4) chrome plated shelf clips included per shelf.
- Shelf support pilasters made of same material as cabinet interior; shelves are adjustable on 1/2" (13 mm) increments.

#### LIGHTING

- Fluorescent interior lighting. Safety shielded.

#### MODEL FEATURES

- Designed to accommodate a variety of beer kegs.
- Evaporator is epoxy coated to eliminate the potential of corrosion.
- Listed under NSF-7 for the storage and/or display of packaged or bottled product.

#### ELECTRICAL

- Unit completely pre-wired at factory and ready for final connection to a 115/60/1 phase - 15 amp dedicated outlet. Cord and plug set included.



115/60/1  
NEMA-5-15R

#### OPTIONAL FEATURES/ACCESSORIES

Upcharge and lead times may apply.

- 6" (153 mm) standard legs.
- 6" (153 mm) seismic/flanged legs.
- 2<sup>1</sup>/<sub>2</sub>" (64 mm) diameter castors.
- 4" (102 mm) diameter castors.
- TrueTrac One liter or wine bottle organizers.
- TrueTrac 12 oz. (355 ml) bottle organizers.
- Double headed draft column.
- Two-way manifold.
- Three-way manifold.
- Draft cap.
- Remote cabinets (condensing units supplied by others; system comes standard with 404A expansion valve and requires R404A refrigerant). Consult factory technical service department for BTU information.

### PLAN VIEW

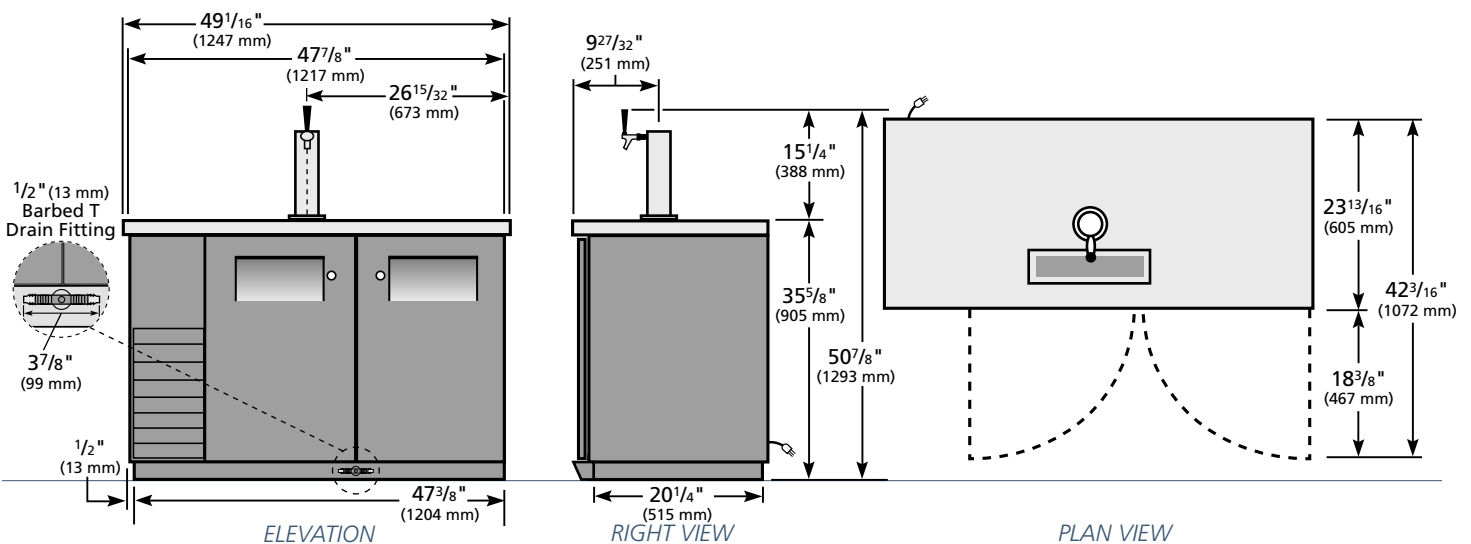

#### WARRANTY

One year warranty on all parts & labor and an additional 4 year warranty on compressor. (U.S.A. only)

METRIC DIMENSIONS ROUNDED UP TO THE NEAREST WHOLE MILLIMETER

SPECIFICATIONS SUBJECT TO CHANGE WITHOUT NOTICE



Model	Elevation	Right	Plan	3D
TDB-24-48	TFSY05E	TFSY05S	TFSY05P	TFSY053

### TRUE FOOD SERVICE EQUIPMENT