



Item# \_\_\_\_\_

# Heavy Duty Griddles

## and Open Burner Combinations

### Manually Controlled



Model # IMGA-3628

#### Standard Features

- NEW** 10<sup>3</sup>/<sub>4</sub>" h. low profile Griddle matches IRB Broilers, IHPA Hot Plates, ITG and IGG Griddles and IR Restaurant Ranges.
- NEW** 4" stainless steel grease trough has a wide 3<sup>1</sup>/<sub>2</sub>" x 2<sup>1</sup>/<sub>2</sub>" drain for easy cleaning.
  - Aeration baffles between burners spread heat across griddle for more even heating.
  - Full width rear flue aids uniform heat distribution across griddle surface.
  - 4" tapered stainless steel splash guard.
  - Quad Burner options: (1) Anti-Clogging burner with full flame and a 7,000 BTU low simmer (2) All-Purpose (3) Saute and (4) Wok Jet.
  - Open burner combinations have 28,000 BTU/hr. lift-off burners and 12" x 12" cast iron top grates. Top grates feature anti-clogging pilot shield.
  - 30,000 BTU/hr. "U" type burner located every 12" for even cooking on entire griddle surface.
  - Each burner has an adjustable gas valve and continuous pilot for instant ignition.
  - Stainless steel front, ledge and sides.
  - Thick <sup>3</sup>/<sub>4</sub>" highly polished steel griddle plate for a wide variety of cooking applications. Optional 1" thick plate also available.
  - Full 24" depth plate for more cooking surface.
- NEW** One gallon capacity, removable grease can.
- NEW** Includes 4" stainless steel adjustable legs.
  - 24", 36", 48", 60" and 72" width models available.
  - One year parts and labor warranty.
  - AGA and CGA design certified and NSF listed.

#### Imperial Heavy Duty Griddles

Imperial provides as standard many of the optional upgrades normally offered at a premium on other Griddle lines. The new look features a stainless steel front, ledge and sides. A new 4" high stainless steel tapered splash guard promotes cleanliness.

Imperial Heavy Duty Griddles are designed for the most demanding foodservice applications. The <sup>3</sup>/<sub>4</sub>" thick, highly polished griddle plate is ideal for a wide variety of cooking requirements and the 24" depth provides maximum cooking surface for peak cooking times. The 30,000 BTU/hr. "U" type burners are strategically located to provide even heating across the entire griddle surface. New features have been added to improve uniform temperatures: aeration baffles are located between burners and a full width rear flue. The high BTU output, total cooking surface and griddle quality assure the best value on the market.

New Heavy Duty Griddle line has a Range Match profile that lines-up with Imperial counter top equipment and restaurant ranges when placed on a standard refrigerated base or equipment stand.

Also available with a built-in refrigerated base. (See Sizzle 'n Chill specification sheet.)



# Heavy Duty Griddles - Manually Controlled

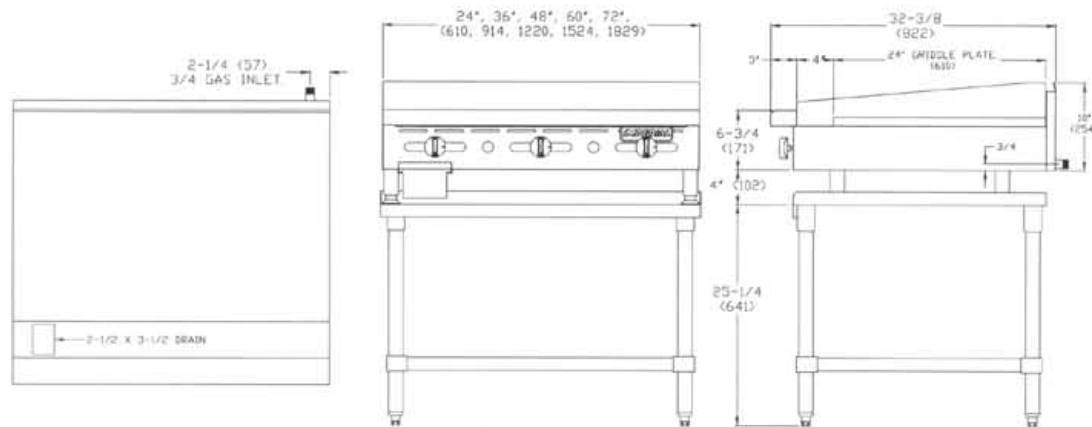

## Heavy Duty Griddles, Manually Controlled

Model#	Griddle Width	Griddle Burners	Overall Width	Total B.T.U.	Ship Weight (Kg)	Ship Weight (Lbs)	Stand Model#	Ship Weight (Kg)	Ship Weight (Lbs)
<b>Manually Controlled Griddles</b>									
IMGA-2428	24"	2	24"	60,000	91	200	IMGS-24	23	50
IMGA-3628	36"	3	36"	90,000	138	305	IMGS-36	32	70
IMGA-4828	48"	4	48"	120,000	163	360	IMGS-48	39	85
IMGA-6028	60"	5	60"	150,000	188	415	IMGS-60	48	105
IMGA-7228	72"	6	72"	180,000	290	640	IMGS-72	62	135
<b>Manually Controlled Griddles with (2) Open Burner Combinations</b>									
IMGA-2428-OB-2	24"	2	36"	116,000	141	310	IMGS-36	32	70
IMGA-3628-OB-2	36"	3	48"	146,000	179	395	IMGS-48	39	85
IMGA-4828-OB-2	48"	4	60"	176,000	231	510	IMGS-60	48	105
IMGA-6028-OB-2	60"	5	72"	206,000	276	610	IMGS-72	62	135
IMGA-7228-OB-2	72"	6	84"	236,000	331	730	IMGS-84	77	170

**Note:** Add "OB-4" to model number and 24" to overall width for 4 Open Burner/Griddle Combination. Open burners are located on right side unless specified. For 1" thick griddle plate add "-1" to model number.  
**Crated Dimensions:** Height = 14" (356) Depth = 36" (914) Width: add 2 1/2" to Griddle width.

### Standard Exterior Finish

- **Stainless Steel:** Front, ledge, grease trough, splash guard and sides. Welded and finished stainless steel seams. Set of four, 4" adjustable legs.
- **Control Knobs:** Durable cast iron, polished chrome finish.

### Griddle Top

- **Griddle Burner:** 30,000 BTU/hr. "U" type located every 12" for even cooking. One adjustable gas valve and standing pilot per burner. Aeration baffles between burners and a full width rear flue provide uniform griddle surface temperature.
- **Griddle Plate:** 3/4" thick, highly polished plate. No breaking-in required. 24" depth. Stainless steel 4" high tapered splash guard.
- **Grease Trough:** 4" wide grease trough for easy cleaning. Large 1 gallon capacity removable grease can.
- **Open Burner Top:** 28,000 BTU/hr. cast iron burners with lift-off burner heads. No gaskets, no screws. Four interchangeable burner heads available: Anti-Clogging is standard, All-Purpose, Saute' and Wok Jet are optional. One standing pilot and manual gas valve for each burner for instant ignition.
- **Burner Top Grates:** 12" x 12" lift-off sections, heavy duty cast iron. Cast-in bowl directs heat upward. Grate features anti-clogging pilot shield.

### Optional Items

1" thick griddle plate; partially grooved plate; open burners. Open burner options: All-Purpose, Saute' or Wok Jet burner head. Extra capacity grease cans; quick disconnect and flexible gas hose; stainless steel stands; and casters (front two casters are locking). Integrated refrigerated base (see Sizzle 'n Chill specification sheet).

### Gas

Manifold pressure is 5.0" W.C. for natural gas or 10.0" for propane gas. Manifold size 3/4" NPT. Specify type of gas and elevation if over 2,000 ft.

### Clearance

For use only on non-combustible surfaces. Provide 0" clearance from non-combustible surfaces and 8" from combustible walls at sides and 7" from rear walls.



Commercial Cooking Equipment

1560 Flower St., Duarte, CA 91010 Phone (626) 357-7411 FAX (626) 359-5909 E-Mail [impsls@imperialrange.com](mailto:impsls@imperialrange.com) Website [imperialrange.com](http://imperialrange.com)

1102 G-1

Imperial reserves the right to change materials and specifications without notice

© 2002 Imperial Commercial Cooking Equipment

Printed in the U.S.A.