

MIXERS



SM200

Gear driven, 20 qts mixer with standard #12 attachment hub for slicer or grinder attachment.



SM201

Belt driven, 20 qts mixer.



SM300

Gear driven, 30 qts mixer with standard #12 attachment hub for slicer or grinder attachment.



SM401

Belt driven, 40 qts mixer.



SM402NA

Belt driven, 40 qts mixer with standard #12 attachment hub for slicer or grinder attachment.



**SM100HV
(meat grinder)**



**SM100CL
(slicer)**

FEATURING SM Series

- 1 stainless steel bowl.
- Mixing hook, whip and flat beater.
- Manual bowl lift.
- From 1/2 HP up to 1 1/2 HP motor, lubricated ball bearings, air cooled with thermal overload protection that automatically shuts the mixer off in an overload situation.
- High torque transmission. Grease lubricated, antifriction ball bearings. Heat treated steel alloy gears.
- 3 positive speeds, see chart on back.
- Bowl guard.
- Emergency stop.
- One year parts and labor limited warranty.

OPTIONAL

- 1 extra stainless steel bowl.
- SM100HV: Meat grinder attachment.
- SM100CL: Vegetable and pepperoni slicer with 3 cheese shredders attachment.

SM Series mixers

For over 18 years, Doyon's planetary SM series mixers have been the most competitive mixers on the market. From 20, 30 and 40 quarts, Doyon offers the most flexible, dependable heavy duty mixers of the industry at a price that can't be beat !

SM200

SM201

SM300

SM401

SM402NA

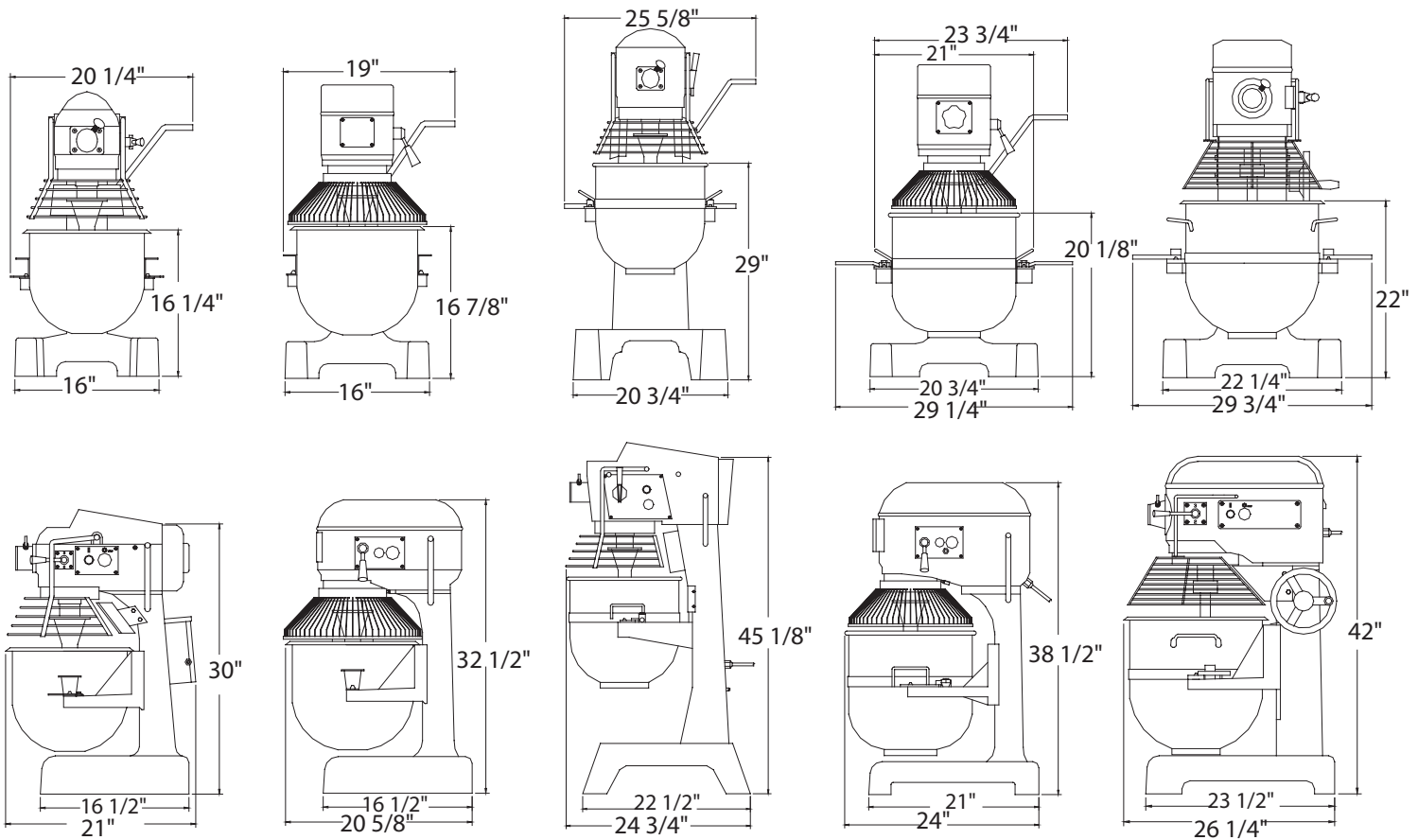

MODEL	CAPACITY quarts (liters)	CRATED WEIGHT	OVERALL EXTERIOR DIMENSIONS			HUB	DOUGH CAPACITY (50% ABSORPTION RATIO)		BOWLS	MOTOR (HP)	SPEEDS (RPM)			VOLTS	AMPS	NEMA
			W	D	H		lb	kg			1ST	2ND	3RD			
SM200	20	250 lb 114 kg	20 1/4" 483 mm	21" 534 mm	30" 762 mm	yes	10	4.5	1	1/2	107	198	361	120	12	5-15P
SM201	20	250 lb 114 kg	19" 483mm	20 5/8" 524 mm	32 1/2" 826 mm	no	10	4.5	1	1/2	120	265	490	120	8	5-15P
SM300	30	465 lb 211 kg	25 1/2" 255 mm	24 3/4" 1597 mm	45 1/8" 1146 mm	yes	15	6.8	1	1	95	176	321	120	16	5-20P
SM401	40	465 lg 211 kg	23 3/4" 603 mm	24" 610 mm	38 1/2" 978 mm	no	20	9	1	1	105	210	323	120	14	5-20P
SM402NA	40	575 lb 261 kg	22 1/4" 565 mm	26 1/4" 667 mm	42" 1067 mm	yes	30	13.6	1	1 1/2	90	170	310	208-240	14	6-20P
SM100HV	-	20 lb 9 kg	<p style="text-align: right;">Other voltages available Specifications and design subject to change without notice.</p>													
SM100CL	-	60 lb 27 kg														



1255, rue Principale
Linière, Beauce, Québec, Canada G0M 1J0

Telephone.: 418-685-3431
Canada: 1-800-463-1636
E-mail : doyon@doyon.qc.ca

Fax: 418-685-3948
U.S.: 1-800-463-4273
Internet : http://www.doyon.qc.ca

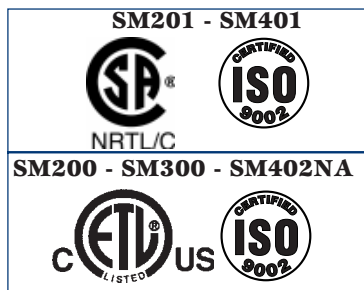

Your local distributor:

