

## 24" Restaurant Ranges



Accommodates  
Full Size Sheet Pans

**2000  
SERIES**

Model # IR-4



New standard Anti-Clogging burner head is shown.  
Anti-clogging pilot shield is designed into the top grate.

### 2000 Series Standard Features

- NEW** Quad Burner options: (1) Anti-Clogging burner with full flame and a 7,000 BTU low simmer is standard; (2) All-Purpose (3) Sauté and (4) Wok Jet.
- NEW** 28,000 BTU lift-off burner heads for high performance cooking and easy cleaning.
- NEW** Anti-clogging pilot shield is designed into the top grate.
- NEW** Chef's depth (26" D) oven accommodates 18" x 26" sheet pans front-to-back.
- NEW** "U"-shaped burner and unique burner baffle distributes heat flow evenly throughout the 27,000 BTU oven.
  - Stainless steel front, ledge, sides, backguard and shelf.
  - 12" x 12" heavy duty cast iron top grates remove easily and safely. Cast-in bowl directs heat to the cooking surface.
  - Top grate design allows pots to slide easily from section to section.
  - 5" wide stainless steel landing ledge provides a functional working area.
  - 20" wide oven is porcelainized on five contact surfaces for easy cleaning.
  - Oven door is removable for easy access, no tools are required.
  - One year parts and labor warranty.
  - AGA and CGA design certified, NSF and CE listed.

### The 2000 Series Restaurant Ranges

Imperial provides as standard many of the optional upgrades normally offered at a premium on other range lines. The 2000 Series Ranges offer new features that provide optimal performance, value and reduce operating costs.



The 28,000 BTU burner heads lift off for easy cleaning and are available in four high performance styles: the Anti-Clogging burner head is standard. All-Purpose, Sauté and Wok Jet burner heads are optional. Burner heads are interchangeable to provide the flexibility of matching the burner style to the specific cooking need. An anti-clogging pilot design saves maintenance costs. A unique Chef's depth 26" oven accommodates 18" x 26" sheet pans front-to-back. For easy cleaning, the door on the standard oven is removable and the interior is porcelainized on all five contact surfaces. An innovative dual heat deflector system provides an even heat flow pattern throughout the 27,000 BTU oven. Cast iron top grates are designed in 12" x 12" sections to be removed easily and safely.

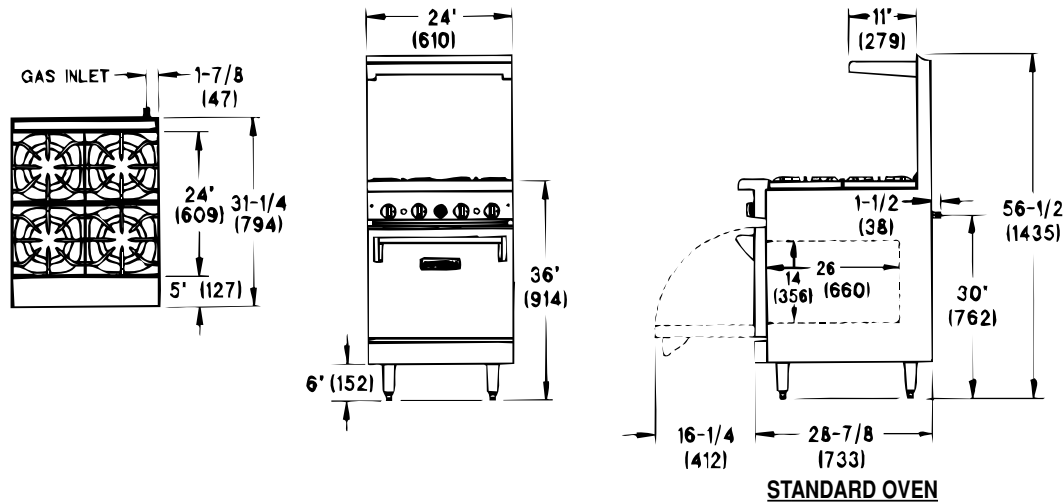

# 2000 SERIES 24" Restaurant Ranges



## 2000 Series 24" Restaurant Ranges

Top Configuration	Model#	Description		Oven Depth	Total B.T.U.	Ship Weight	
		Top	Base			(Kg)	(Lbs)
	IR-4	(4) Open Burners	- w/(1) 20" Oven - w/(1) Cabinet Base	26"	139,000 112,000	210 183	465 405
	IR-2-G12	(2) Open Burners and (1) 12" Griddle	- w/(1) 20" Oven - w/(1) Cabinet Base	26"	103,000 76,000	213 185	470 410
	IR-G24	(1) 24" Griddle	- w/(1) 20" Oven - w/(1) Cabinet Base	26"	67,000 40,000	224 196	495 435

**Note:** Add "XB" to model number for Cabinet Base.

**Crated Dimensions:** 39" (991mm) D x 35" (889mm) H x 26 1/2" (673mm) W

### Standard Exterior Finish

- **Stainless Steel:** Front oven door, sides, landing ledge, back guard with shelf, control panel and kick plate. Welded and finished stainless steel seams.
- **Control Knobs:** Durable cast metal, polished chrome finish.
- **Legs:** Chrome plated 6" legs with adjustable feet.

### Range Tops

- **Open Burners:** 28,000 BTU/hr. lift-off burner heads. No gaskets, no screws. Four interchangeable burner heads available: Anti-Clogging is standard; the All-Purpose, Sauté and Wok Jet burner heads are optional. One standing pilot for each burner. Removable one piece drip tray.
- **Top Grates:** 12" x 12" lift-off sections, heavy-duty cast iron. Cast-in bowl directs heat upward. Top grate design includes an integrated pilot shield.
- **Griddles:** Highly polished 3/4" plate with 3" wide stainless steel grease trough. 20,000 BTU burner for every 12" of griddle surface. Located on left side of range top. Manual controls are standard, thermostatic controls optional.
- **Hot Tops:** Heavy-duty casting with heat retaining projections underneath to absorb and diffuse heat. One 20,000 BTU/hr. "U" shaped burner every 12". Manual controls. Polished surface.

### Oven Specifications

- **Construction:** 12 gauge construction with welded front frame. Fully insulated with non-sag fiberglass. Porcelainized oven interior includes: sides, rear, deck and door linings. Oven burner provides 27,000 BTU/hr. Equipped with one heavy-duty locking chrome plated rack.
- **Controls:** Thermostat adjustable from 150°F to 500°F. 100% safety pilot with matchless, push button ignition.
- **Dimensions:** 20" wide x 26" deep x 14" high standard 20" oven interior dimensions. 26" Chef's depth oven accommodates sheet pans front to back.

### Optional Items

Extra chrome rack; reinforcement channels for mounting cheese melter/salamander; thermostatic controls for griddles; grooved griddles; stainless steel stub backs; and casters.

### Gas

Manifold pressure is 5.0" W.C. for natural gas or 10.0" for propane gas. Manifold size 3/4" NPT. 3/4" pressure regulator supplied with equipment to be installed at time of connection. Specify type of gas and elevation if over 2000 ft.

### Clearance

For use only on non-combustible floors. Legs or casters are required for non-combustible floors; or 2" overhang is required when curb mounted. Provide 0" clearance from non-combustible surfaces and 8" from combustible surfaces.



Commercial Cooking Equipment

1560 Flower St., Duarte, CA 91010 Phone (626) 357-7411 FAX (626) 359-5909 E-Mail [impsls@imperialrange.com](mailto:impsls@imperialrange.com) Website [imperialrange.com](http://imperialrange.com)