



Item# _____

36" Restaurant Ranges



2000 SERIES

Model# IR-6



New standard Anti-Clogging burner head is shown. Anti-clogging pilot shield is designed into the top grate.

2000 Series Standard Features

- NEW** Quad Burner options: (1) Anti-Clogging burner with full flame and a 7,000 BTU low simmer is standard; (2) All-Purpose (3) Saute´ and (4) Wok Jet.
- NEW** 28,000 BTU lift-off burner heads for high performance cooking and easy cleaning.
- NEW** Anti-clogging pilot shield is designed into the top grate.
- NEW** Chef's depth (26" D) standard oven allows 18" x 26" sheet pans to be rotated left-to-right and front-to-back.
- NEW** Stamped inner door provides better heat retention.
- NEW** "U"-shaped burner and unique burner baffle distributes heat flow evenly throughout the 35,000 BTU oven.
 - Stainless steel front, ledge, sides, backguard and shelf.
 - 12" x 12" heavy duty cast iron top grates remove easily and safely. Cast-in bowl directs heat to the cooking surface.
 - Top grate design allows pots to slide easily from section to section.
 - 5" wide stainless steel landing ledge provides a functional working area.
 - 26 1/2" wide oven is porcelainized on five contact surfaces for easy cleaning.
 - Oven door is removable for easy access, no tools are required.
 - One year parts and labor warranty.
 - AGA and CGA design certified, NSF and CE listed.

The 2000 Series Restaurant Ranges

Imperial provides as standard many of the optional upgrades normally offered at a premium on other range lines. The 2000 Series Ranges offer new features that provide optimal performance, value and reduce operating costs.

The 28,000 BTU burner heads lift off for easy cleaning and are available in four high performance styles: the Anti-Clogging burner head is standard. All-Purpose, Saute´ and Wok Jet burner heads are optional. Burner heads are interchangeable to provide the flexibility of matching the burner style to the specific cooking need. An anti-clogging pilot design saves maintenance costs. A unique Chef's depth 26" standard oven accommodates 18" x 26" sheet pans front-to-back and left-to-right. For easy cleaning, the door on the standard oven is removable and the interior is porcelainized on all five contact surfaces. An innovative dual heat deflector system provides an even heat flow pattern throughout the 35,000 BTU oven. Cast iron top grates are designed in 12" x 12" sections to be removed easily.



2000 SERIES 36" Restaurant Ranges

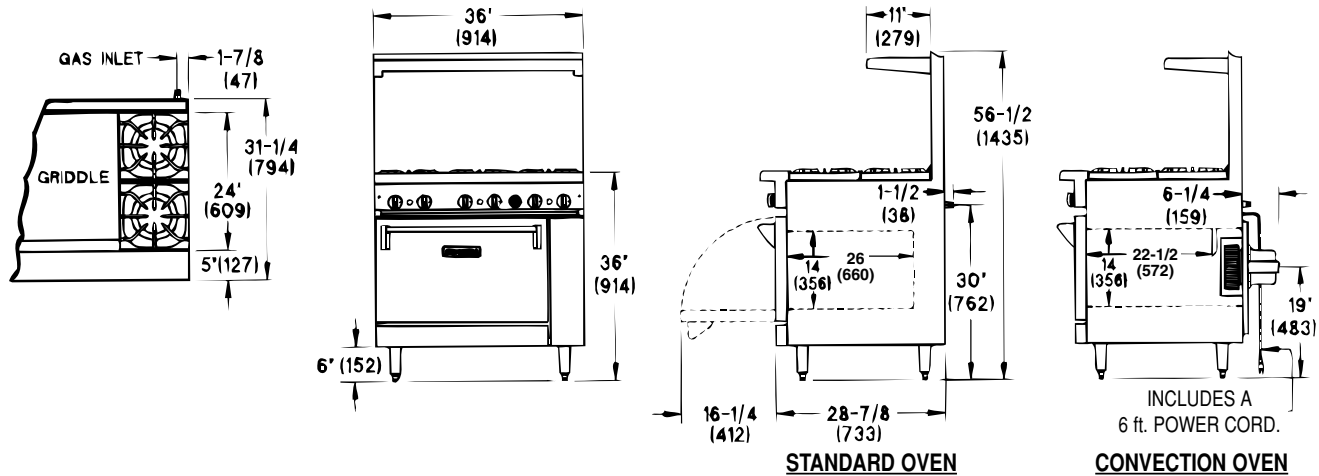

Imperial 2000 36" Restaurant Ranges

Top Configuration	Model#	Description	Oven Depth	Total B.T.U.	Ship Weight (Kg)	Ship Weight (Lbs)
	IR-6	(6) Open Burners - w/(1) 26 1/2" W Standard Oven - w/(1) 26 1/2" W Convection Oven - w/(1) Cabinet Base	26" 22 1/2"	203,000 198,000 168,000	274 301 246	605 665 545
	IR-4-G12	(4) Open Burners with (1) 12" Griddle - w/(1) 26 1/2" W Standard Oven - w/(1) 26 1/2" W Convection Oven - w/(1) Cabinet Base	26" 22 1/2"	167,000 162,000 132,000	283 310 256	625 685 565
	IR-2-G24	(2) Open Burners with (1) 24" Griddle - w/(1) 26 1/2" W Standard Oven - w/(1) 26 1/2" W Convection Oven - w/(1) Cabinet Base	26" 22 1/2"	131,000 126,000 96,000	288 314 260	635 695 575
	IR-G36	(1) 36" Griddle - w/(1) 26 1/2" W Standard Oven - w/(1) 26 1/2" W Convection Oven - w/(1) Cabinet Base	26" 22 1/2"	95,000 90,000 60,000	297 319 269	655 705 595
	IR-4-RG12	(4) Open Burners with (1) 12" Raised Griddle/Broiler - w/(1) 26 1/2" W Standard Oven - w/(1) 26 1/2" W Convection Oven - w/(1) Cabinet Base	26" 22 1/2"	167,000 162,000 132,000	283 310 256	625 685 565
	IR-4-S18	(4) Open Burners with (2) 18" W Grates - w/(1) 26 1/2" W Standard Oven - w/(1) 26 1/2" W Convection Oven - w/(1) Cabinet Base	26" 22 1/2"	147,000 142,000 112,000	272 298 244	600 660 540

Note: Add "C" to model number for Convection Oven. Add "XB" to model number for Cabinet Base model.

Crated Dimensions: 39" (991mm) D x 35" (889mm) H x 38 1/2" (978mm) W

Standard Exterior Finish

- **Stainless Steel:** Front oven door, sides, landing ledge, backguard with shelf, control panel and kick plate. Welded stainless steel seams.
- **Control Knobs:** Durable cast metal, polished chrome finish.

Range Tops

- **Open Burners:** 28,000 BTU/hr. lift-off burner heads. No gaskets, no screws. Four interchangeable burner heads available: Anti-Clogging is standard; the All-Purpose, Sauté and Wok Jet burner heads are optional. One standing pilot for each burner. Removable one piece drip tray.
- **Top Grates:** 12" x 12" lift-off sections, heavy-duty cast iron. Cast-in bowl directs heat upward. Top grate design includes an anti-clogging pilot shield.
- **Griddles:** Highly polished 3/4" plate with 3" wide stainless steel grease trough. 20,000 BTU burner for every 12" of griddle surface. Located on left side of range top. Manual controls are standard, thermostatic controls are optional.
- **Raised Griddle with Broiler:** Available in 12", 24" and 36" widths. 3/4" plate with manual control only. 20,000 BTU/hr. burner with heat deflector every 12". Located on right side of range top. Large griddle grease can. Chrome plated broiler rack is removable. Large full width broiler drip tray.
- **Hot Tops:** Heavy-duty casting with heat retaining projections underneath to absorb and diffuse heat. One 20,000 BTU/hr. "U"-shaped burner every 12". Manual controls. Polished surface.

Oven Specifications

- **Chef's Depth Standard Oven:** 26 1/2" wide x 26" deep x 14" high. 12 gauge construction with welded front frame. Fully insulated with non-sag fiberglass. Porcelainized oven interior includes: sides, rear, deck and door linings. Oven "U" burner provides 35,000 BTU/hr. One heavy-duty locking chrome plated rack.
- **Convection Oven:** 26 1/2" wide x 22 1/2" deep x 14" high. 1/4 HP, 1725 RPM blower motor (120VAC-60 HZ - 1Ph) with 5 amp draw. Provided with 3-prong 6' (1829mm) power cord. 30,000 BTU/hr. "U" burner with electronic ignition. Includes three heavy duty chrome plated racks supported by chrome plated guides. Three-position switch for cooking or cool down; burner "on" indicator light; and one hour manual timer.
- **Controls:** Thermostat adjustable from 150°F to 500°F. 100% safety pilot with matchless, push button ignition.

Optional Items: Extra chrome rack; reinforcement channels for mounting cheese melter/salamander; thermostatic controls for griddles; grooved griddles; stainless steel stub backs; and casters.

Gas: Manifold pressure is 5.0" W.C. for natural gas or 10.0" for propane gas. Manifold size 3/4" NPT. 3/4" pressure regulator supplied with equipment to be installed at time of connection.

Clearance: For use only on non-combustible floors. Legs or casters are required for non-combustible floors; or 2" overhang is required when curb mounted. Provide 0" clearance from non-combustible surfaces and 8" from combustible surfaces.



Commercial Cooking Equipment