



**TRUE FOOD SERVICE EQUIPMENT, INC.**

St. Charles Industrial Center • P.O. Box 970 • O'Fallon, Missouri 63366  
 (636)240-2400 • FAX (636)272-2408 • (800)325-6152 • www.truemfg.com  
 Parts Dept. (800)424-TRUE • Parts Dept. FAX# (636)272-9471

Project Name: \_\_\_\_\_

A/A #

Location: \_\_\_\_\_

Item #: \_\_\_\_\_ Qty: \_\_\_\_\_

SIS #

Model #: \_\_\_\_\_

Model:  
**TSSU-60-24M-B-ST**

**Food Prep Table:**  
*Mega Split Top Sandwich/Salad Unit*



**TSSU-60-24M-B-ST**

- ▶ True's salad/sandwich units are designed with enduring quality that protects your long term investment.
- ▶ Oversized, environmentally friendly (134A) forced-air refrigeration system holds 33°F to 41°F (.5°C to 5°C).
- ▶ Complies with and listed under ANSI/NSF-7-1997-6.3.
- ▶ All stainless steel front, top and cabinet ends. Matching aluminum finished back.
- ▶ Stainless steel, patented, foam insulated lids and hoods maintain colder pan temperatures, lock in freshness and minimize condensation. Removable for easy cleaning.
- ▶ 87/8" (226 mm) full length removable cutting board included. Sanitary, high density, NSF approved polyethylene provides tough preparation surface.
- ▶ Foamed-in-place, high density polyurethane insulation (CFC free).
- ▶ Heavy duty PVC coated wire shelves.

**ROUGH-IN DATA**

Specifications subject to change without notice.

Chart dimensions rounded up to the nearest 1/8" (millimeters rounded up to next whole number).

Model	Doors	Capacity (Cu. Ft.) (liters)	Shelves	Pans (top)	Cabinet Dimensions (inches) (mm)			HP	Voltage	Amps	NEMA Config.	Cord Length (total ft.) (total m)	Crated Weight (lbs.) (kg)
					L	D†	H*						
TSSU-60-24M-B-DS-ST	2	15.5 439	4	24	60 <sup>3</sup> / <sub>8</sub> 1534	34 <sup>1</sup> / <sub>8</sub> 867	40 <sup>3</sup> / <sub>8</sub> 1026	1/3 1/3	115/60/1 230-240/50/1	7.8 4.2	5-15P ▲	7 2.13	355 162

\* Height does not include 6 1/4" (159 mm) for castors or 6" (153 mm) for optional legs.

▲ Plug type varies by country.

† Depth does not include 1" (26 mm) for rear bumpers.

	<b>APPROVALS:</b>	<b>AVAILABLE AT:</b>
10/05	Printed in U.S.A.	

Model:

**TSSU-60-24M-B-ST**

**Food Prep Table:**

*Mega Split Top Sandwich/Salad Unit*



**STANDARD FEATURES**

**DESIGN**

- True's commitment to using the highest quality materials and oversized refrigeration systems provides the user with colder product temperatures, lower utility costs, superior food safety and the best value in today's food service marketplace.

**REFRIGERATION SYSTEM**

- Factory engineered self-contained, capillary tube system using environmentally friendly (CFC free) 134A refrigerant.
- Oversized, factory balanced refrigeration system with guided airflow to provide uniform temperature in food pans and cabinet interior.
- Forced-air design holds 33°F to 41°F (.5°C to 5°C) product temperature in food pans and cabinet interior. Complies with and listed under ANSI/NSF-7-1997-6.3.
- Condensing unit access in back of cabinet, slides out for easy maintenance.

**CABINET CONSTRUCTION**

- Exterior - stainless steel front, top and cabinet ends. Matching aluminum finished back.
- Interior - attractive, NSF approved, white aluminum liner. 300 series stainless floor with coved corners.
- Insulation - entire cabinet structure and solid doors are foamed-in-place using high density, CFC free, polyurethane insulation.
- 5" (127 mm) diameter stem castors - locks provided on front set. 36" (915 mm) work surface height.

**DOORS**

- Stainless steel exterior with white aluminum liner to match cabinet interior.
- Positive seal self-closing doors with 90° stay open feature. Doors swing within cabinet dimensions.
- Each door fitted with 12" (305 mm) long recessed handle that is foamed-in-place with a sheet metal interlock to insure permanent attachment.
- Magnetic door gaskets of one piece construction, removable without tools for ease of cleaning.

**SHELVING**

- Four (4) adjustable, heavy duty PVC coated wire shelves 27<sup>1</sup>/<sub>2</sub>" L x 16" D (699 mm x 407 mm). Four (4) chrome plated shelf clips included per shelf.
- Shelf support pilasters made of same material as cabinet interior; shelves are adjustable on 1/2" (13 mm) increments.

**MODEL FEATURES**

- Evaporator is epoxy coated to eliminate the potential of corrosion.
- 8<sup>7</sup>/<sub>8</sub>" (226 mm) full length removable cutting board. Sanitary, high-density, NSF approved polyethylene provides tough preparation surface.
- Stainless steel, patented, foam insulated lids and hood keep pans' temperature colder, lock in freshness and minimize condensation. Removable for easy cleaning.
- Comes standard with 24 (1/6 size) 6<sup>7</sup>/<sub>8</sub>" L x 6<sup>1</sup>/<sub>4</sub>" W x 4" D (175 mm x 159 mm x 102 mm) clear polycarbonate, NSF approved, food pans in countertop prep area. Also accommodates 6" (153 mm) and 8" (204 mm) deep food pans.

- Countertop pan opening designed to fit varying size pan configurations with available pan divider bars. Varying size pans supplied by others.
- NSF-7 compliant for open food product.

**ELECTRICAL**

- Unit completely pre-wired at factory and ready for final connection to a 115/60/1 phase - 15 amp dedicated outlet. Cord and plug set included.



115/60/1  
NEMA-5-15R

**OPTIONAL FEATURES/ACCESSORIES**

- Upcharge and lead times may apply.
- 230 - 240V / 50 Hz.
  - 6" (153 mm) standard legs.
  - 6" (153 mm) seismic/flanged legs.
  - 2<sup>1</sup>/<sub>2</sub>" (64 mm) diameter castors.
  - Additional shelves.
  - Single utility shelf.
  - Double utility shelf.
  - Sneezeguard.
  - 8<sup>7</sup>/<sub>8</sub>" (226 mm) deep, 1/2" (13 mm) thick, composite cutting board.
  - Crumb catcher. Requires crumb catcher cutting board.
  - Pan dividers.
  - ADA compliant models with 34" (864 mm) work surface height.
  - Remote cabinets (condensing unit supplied by others; system comes standard with 404A expansion valve and requires R404A refrigerant), consult factory technical service department for BTU information.

**PLAN VIEW**

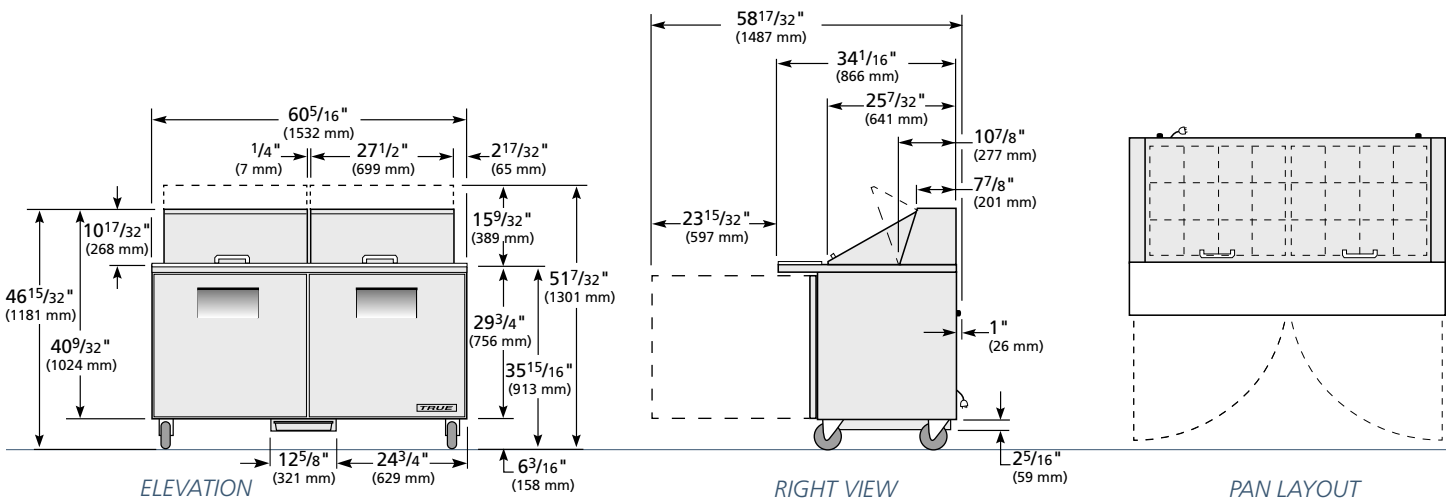

**WARRANTY**  
 One year warranty on all parts and labor and an additional 4 year warranty on compressor. (U.S.A. only)

METRIC DIMENSIONS ROUNDED UP TO THE NEAREST WHOLE MILLIMETER  
 SPECIFICATIONS SUBJECT TO CHANGE WITHOUT NOTICE



Model	Elevation	Right	Plan	3D
TSSU-60-24M-B-ST	TFNY64E	TFNY34S	TFNY64P	TFNY643

**TRUE FOOD SERVICE EQUIPMENT**