



PORTABLE LAMP WARMER

Model LW-2

The Hatco Portable Lamp Warmer will hold your food products at serving temperatures. The specially designed powdercoated stand keeps food holding pans above the countertop, providing an effective insulation to prolong serving times.

FLEXIBILITY

This lamp warmer holds full size and half size pans of appetizers, chicken wings, or other hot foods. Ideal for restaurants, cafeterias, concession stands, convenience stores, and delis, this warmer has an adjustable stand that varies the height 14¹/₄" to 19¹/₂" (368-495 mm) from the bottom of the lamp shroud to the countertop.

Blend the Lamp Warmer with the décor by choosing one of six powdercoated *Designer* colors: warm red, black, gray granite, white granite, navy blue, and hunter green.

QUALITY

The following features assure the finest performance for years to come:

- The LW-2 has a 6' (1829 mm) cord and plug with in-line power switch located outside of the heat zone.
- Vented lamp shades with heavy-duty sockets.
- The Hatco Lamp Warmer comes with two 250-watt clear uncoated heat bulbs. Uncoated red, coated red, and coated clear bulbs are available.



Model LW-2
with accessory
food pans



HATCO CORPORATION P.O. Box 340500 Milwaukee, WI 53234-0500 U.S.A.
(800) 558-0607 • (414) 671-6350 • Fax (800) 543-7521 • Int'l. Fax (414) 671-3976
www.hatcocorp.com • E-mail: equipsales@hatcocorp.com



PORTABLE LAMP WARMER

Model LW-2

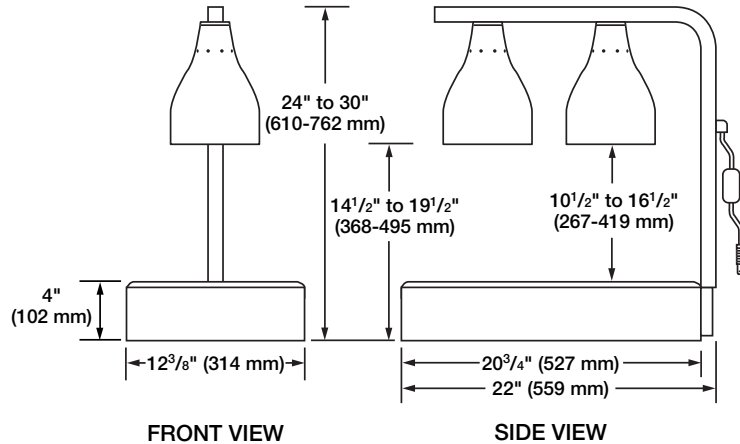

SPECIFICATIONS

Model [▲]	Watts	Amps	Shipping Weight
LW-2	500	4.2	13 lbs. (6 kg)

▲ When no color is specified, color will be gray granite.

DIMENSIONS

12³/₈"W x 22"D x 24"-30"H (314 x 559 x 610-762 mm).

VOLTAGE

120 volts, single phase (uses NEMA 5-15P).
Export voltages available.

CORD LOCATION

Back of adjustable stand near top.

PLUG CONFIGURATIONS

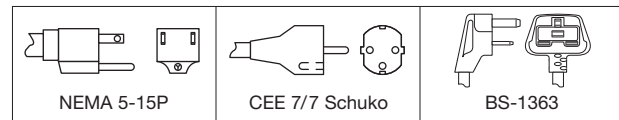

OPTIONS (NOT FOR RETROFIT)

- Designer Colors: Warm Red, Black, Gray Granite, White Granite, Navy Blue, Hunter Green

ACCESSORIES

- 250 Watt Clear Bulb, Coated
 250 Watt Red Bulb, Uncoated, 120V only
 250 Watt Red Bulb, Coated, 120V only
 5 Pleat Hardcoated French Fry Box Ribbon
 8 Pleat Hardcoated French Fry Bag Ribbon

PRODUCT SPECS

Lamp Warmer

The Lamp Warmer shall be a Hatco Modelas manufactured by the Hatco Corporation, Milwaukee, WI 53234 U.S.A.

The Lamp Warmer shall be rated atwatts,volts, and beinches (millimeters) in overall width. It shall consist of a powdercoated stand, two vented lamp shades with two uncoated 250-watt heat bulbs, an adjustable stand that varies

the height 14¹/₂" to 19¹/₂" (368-495 mm) from the bottom of the lamp shroud to the countertop, and a 6' (1829 mm) cord and plug with an in-line power switch.

Accessories shall include 250-watt coated clear, coated red, uncoated red bulbs, five pleat hardcoated fry box ribbon, and an eight pleat hardcoated fry bag ribbon.