

IMPINGER® X2 DIGITAL ADVANTAGE SERIES DUAL BELT CONVEYORIZED GAS FIRED OVEN

MODEL 3262-2



Approved by The Canadian Standards Association

Lincoln® IMPINGER X2

FEATURES

- Impinger X2 uses hot air under pressure which surrounds food with small jets of hot air. This allows for rapid heating, cooking, baking and crisping of foods, two to four times faster than conventional ovens, depending on food product cooked.
- Uniform heating/cooking of food products offers a wide tolerance for rapid baking at a variety of temperatures.
- Variable speed conveyors move products through the oven one after another, improving product flow during cooking and drastically reducing labor.
- Safety of conveyorized product movement is a definite advantage over batch type ovens, as it eliminates the need for constant tending.
- Customer specific air fingers on top and bottom allow for the heat to be adjusted and controlled by zoning.

DIGITAL CONTROLS

The digital control panel is located at the back right of the oven and has power fan, burner and conveyor on-off switch. It also has one temperature control for the entire oven and conveyor speed controls for every belt. The LED readout displays actual cavity temperature in degrees (F° or C°), conveyor belt speeds and thermostat indicator light. A diagnostic troubleshooter is an optional accessory which provides 39 different check points within the oven simply by attaching it to the diagnostic plug at the bottom of the control box. All ovens are digitally calibrated at the factory, reducing the need for periodic calibration.



Pizzaovens.com

1.877.FOR.OVEN
367.6836

Since 1999

GENERAL

Double your capacity with Impinger X2 ovens. Each Impinger X2 has two conveyors in each baking chamber and can be stacked two ovens high. Their front removable panel allows for easier access to internal components. A double stack of ovens will provide 4 conveyor belts for cooking. Each belt may be split for more bake time flexibility. The 3262-2 has a 32" wide conveyor belt, and 62" long baking chamber, as well as a 3" opening above the conveyor belt. The 3262-2 oven has in excess of 50% more capacity than the 3240-2, and 13% more capacity than competitive models on a belt-for-belt basis. Temperature is adjustable from 250°F (121°C) to 600°F (316°C). Conveyor speed is adjustable from 2:15 minutes to 16 minutes cooking time. The front panel is completely removable allowing easy access to the fingers and the patented front removable conveyor. Front panel has an optional accessory door which allows product to be placed on the moving conveyor inside the baking chamber when a shorter cook cycle is desired. Air distribution fingers are removable through the front door for easy cleaning. Crumb pans are located below the conveyor belt outside the baking chamber.

CONSTRUCTION

Interior and exterior are fabricated from No.4 finish stainless steel. The air distribution system consists of a 2 squirrel cage fans powered by a 3 hp, AC Motor. The heated air is forced through six (6) distribution fingers located with two above the top belt, two between the belts and two below the bottom belt in the baking chamber. Each finger has the required number of holes to create the air impingement effect on the food product passing through the baking chamber on the conveyor belt. The conveyor belt is a flexible stainless steel design with capacity for 32" (784mm) wide product and a travel distance of 100" (2352mm), of which 62" (980mm) is in the baking chamber. The direct drive conveyor system is powered by DC motors with external reversing switches on the rear of the motor control box for installations requiring opposite belt travel.

Item No. _____

IMPINGER® X2 DIGITAL ADVANTAGE SERIES
DUAL BELT CONVEYORIZED GAS FIRED OVEN

Endis
Lincoln®

IMPINGER® X2 DIGITAL ADVANTAGE SERIES DUAL BELT CONVEYORIZED GAS FIRED OVEN

MODEL 3262-2

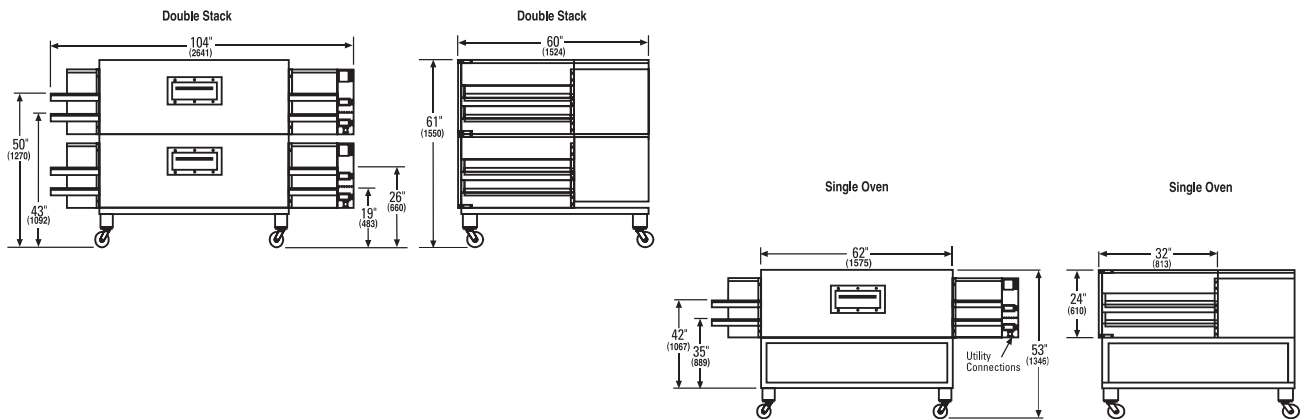

GAS SERVICE: Gas Control system has a manual shut-off valve, internal pressure regulator (factory preset at 3 1/2" water column/ 87 kPa or 8.70 mbar for **Natural Gas**, 10" water column/2.48 kPa or 24.87 mbar for **LP gas**), and an electric solenoid operated main gas valve. Heat is supplied by one (1) power burner rated at 200,000 BTU/Hr. (126MJ) with electronic ignition. Natural gas requires 8" WC mbar inlet with maximum allowable of 14" WC mbar. LP gas requires 13" with maximum allowable of 14" WC. Gas line from meter to ovens should be 2" for natural gas and 1 1/2" for propane. AGA/CGA design approved flexible connection to each oven must be 3/4" NPT and length must not exceed 6 ft. (1829mm).

ELECTRICAL SERVICE: Each oven requires standard 208/240V service. Customer must specify 1 or 3 phase. It is recommended that a separate 20 amp - circuit breaker be provided for each oven deck.

VENTILATION: Ventilation is required. Local codes prevail. These are the "authority having jurisdiction" as stated by the National Fire Protection Association, Inc. in NFPA 96-1994. Consult Impinger X2 Installation and Operations Manual for ventilation recommendations.

SPACING: The oven must have 1" (24.5mm) of clearance from combustible surfaces and 24" (610mm) clearance on both sides from other cooking equipment. A permanently installed oven requires approximately 3ft. (882mm) of clearance overall to allow for removal of the conveyor and protective guards for cleaning. The conveyor is removed from the front of the oven.

WARRANTY: All new Impinger® X2 ovens come with a one year parts/labor warranty. Defective parts of the original equipment on all installed ovens are warranted for one year from the date of "START-UP/CHECK-OUT."

NOTE: A site inspection is mandatory before purchase.

Phase	Voltage	HZ	Amp	Grounding	Plug
Single Phase	208/240	60	13	2 pole, 3 wire with ground	NEMA L14-20P
Three Phase	208/240	60	10	3 pole, 4 wire with ground	NEMA L21-20P

Fuel Type	Configuration	Min. Gas Pipe Size	Gas Shut-Off Valve Size	Gas Supply Pressure		Manifold Pressure (WC)	Power
				Minimum	Maximum		
Natural Gas	Single or Double	2" NPT (50.*)	3/4" NPT ea. oven (19.1)	8" (203)	14" (267)	3.5" (88.9)	200,000 BTU/HR per chamber
Propane	Single or Double	1.5" NPT (38.1)	3/4" NPT ea. oven (19.1)	13" (279)	17" (330)	10" (254)	200,000 BTU/HR per chamber

Metric Dimensions for models: Width: 2641 mm; Depth: 1524 mm; Height Single Stack: 1348 mm; Height Double Stack: 1550 mm.

NOTE: If double stacked, each oven must be wired separately to carry rated load. Each oven requires a "dedicated neutral". U.S. Patent pending.



Pizzaovens.com

1.877.FOR.OVEN
367.6836

Since 1999

www.lincolnfp.com

