

GHIR44 INFRARED BROILER



SPECIFICATIONS:

Battery matching heavy-duty single deck gas infrared broiler with finishing oven over the broiler and storage base under the broiler. Model No. GHIR44, manufactured by Vulcan-Hart. Stainless steel front, top and two 6" adjustable front legs. Power blower to mix primary and secondary air with (natural) (propane) gas. Air and gas mixture to move through overhead perforated ceramic tile infrared generators. Four 20,000 BTU/hr. ceramic tile faced burners reach approximately 1600°F through two infinite heat valves with high and low positions. 80,000 total BTU/hr. input. Pilot lights and pressure regulator. Spring balanced broiler grid area to be 25½"w x 29½"d. Grid is made of cold rolled steel bars and mounted on roller bearings. Insulated external handle and adjustable to five locking broiling levels. Contains an above broiler au gratin oven with interior dimensions: 26" x 28" x 10". Bottom storage base has two doors. Both sides are finished with heat resistant paint.

Exterior dimensions: 34"w x 38¼"d x 82"h.

CSA design certified. NSF listed.

SPECIFY TYPE OF GAS AND FINISH WHEN ORDERING

- GHIR44** With Au gratin oven and lower storage area

STANDARD FEATURES

- Stainless steel front, top and legs.
- High production infrared broiler with power blower supplied primary and secondary air.
- Reaches 1600°F broiling temperatures quickly and maintains broiling efficiency during peak hours under repeated loading.
- Radiant infrared rays reduce broiling time up to 50% on many products.
- Quick preheating allows broiler to be turned off in slow periods.
- Spring balanced 5 position grid for raising and lowering.
- Porcelain enameled steel liners in broiler compartment.
- Four foot 120V power cord.
- Gas pressure regulator.
- Grid area 700 sq. in.; 25½" x 29½".
- Grid moves on roller bearings.
- Cold rolled steel grid bars for marking.
- Insulation between outer and inner walls.
- Au gratin oven.
- One year limited parts and labor warranty.

OPTIONS

- Stainless steel finishing back panel.
- Stainless steel side(s).
- Stainless steel front top ledge.
- IR44 - less legs on 1⅝" base.
- Rear gas connection.
- Second year extended limited parts and labor warranty.

ACCESSORIES

- Quick disconnect gas hose.

IMPORTANT

1. A properly sized gas pressure regulator suitable for battery or single unit application must be furnished and installed. Natural gas 5.0" W.C., propane gas 10.0" W.C.
2. An adequate ventilation system is required for commercial cooking equipment. Information may be obtained by writing to the National Fire Protection Association, Batterymarch Park, Quincy, MA 02269. When writing refer to NFPA No. 96.
3. These units are manufactured for installation in accordance with ANSZ223.1a (latest edition), National Fuel Gas Code. Copies may be obtained from the American Gas Association, 1515 Wilson Blvd., Arlington, VA 22209.
4. This broiler requires a 6" clearance at both sides and rear adjacent to combustible construction.
5. This appliance is manufactured for commercial installation only and is not intended for home use.

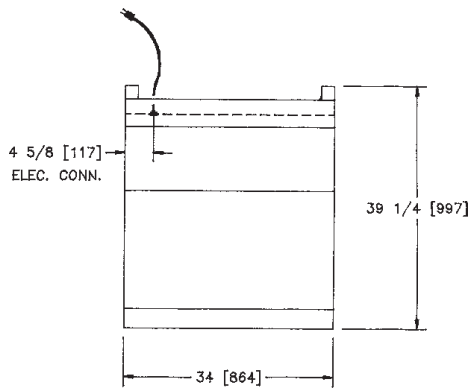

Top View

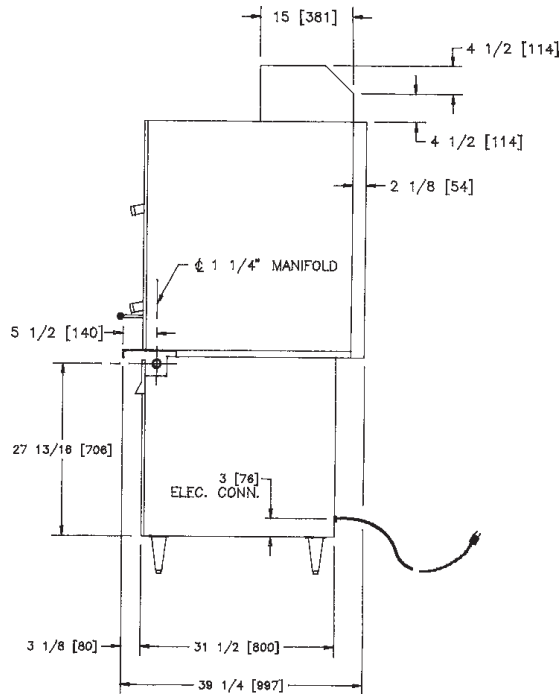

Side View

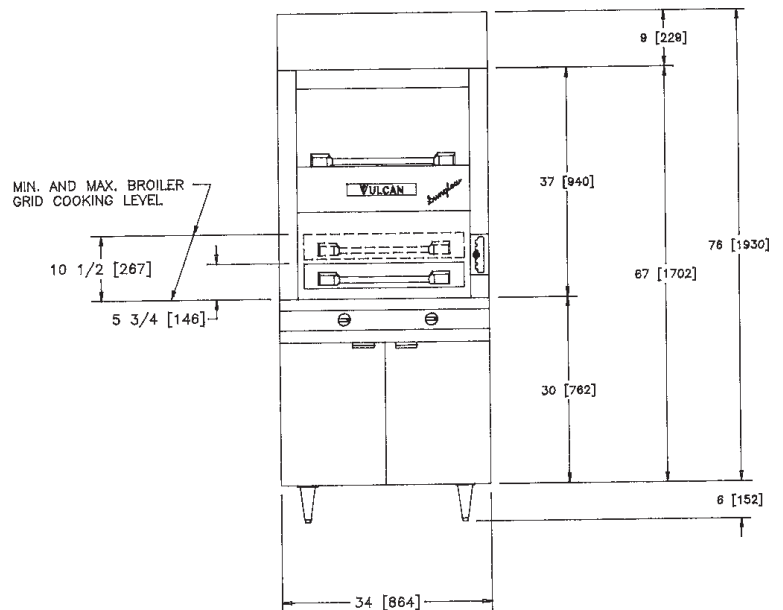

Front View

MODEL GHIR44

Overall Dimensions

Width	34" (864 mm)
Depth	38 1/4" (972 mm)
Height, including 6" legs	82" (2083 mm)
Approx. Shp. Wt.	825 lbs. (374 kg)

Broiler Grid Overall

Width	25 1/2" (648 mm)
Depth	29 1/2" (749 mm)
BTU/hr. Rating	Total 80,000

Finishing Oven Compartment

Width	26" (650 mm)
Depth	28" (711 mm)
Height	10" (254 mm)
Gas Manifold Across Front	1 1/4" std. pipe (32 mm)
Flue Collar	6" (152 mm) x 12" (305)

NOTE: In line with its policy to continually improve its products, Vulcan-Hart Company reserves the right to change materials and specifications without notice.